

Akrapovic Racing system is designed for riders who demand maximum performance from their motorcycle. System is almost 10 kg lighter, if compared to the stock exhaust system and feature exceptional production quality, hi-tech materials and of course increased engine performance combined with pure racing sound output. The Racing system uses stainless steel header tubes and link pipe. We offer titanium or carbon-fiber mufflers. System is not street legal and is designed for racing purpose.

PERFORMANCE

Measurements of the Akrapovic EVOLUTION system on the YAMAHA YZF R1 (without muffler insert):

Power & Torque: The power increase with the Akrapovic system is substantial, and can be seen from 5000 rpm right to the top of the range. At 10250 rpm we measured 141.2 HP, with a max. power increase of 14.1 HP at 10300 rpm. The system's effect on the torque and power curve is huge and strongest at midrange rpm. The main increase starts at around 2500 rpm and continues right into the over-rev range. All this will help you shave lap times and result in a much smoother ride.



PERFORMANCE			
	stock	AKRAPOVIC	max. increased power
max. rear wheel power HP / rpm <small>(measured on SuperFlow Cycle Dyn)</small>	128.0/9800	141.2/10250	14.1/10300

ADDITIONAL DATA					
weight comparison (kg)	stock	AKRAPOVIC		difference	
	14.85	RACING	EVOLUTION	stock - RACING	stock - EVOLUTION
		5.0	-	9.85	-

noise measurements (dB / rpm)	stock	AKRAPOVIC
		92/4800
legal for street use	NO	

Technical specifications of Akrapovic exhaust systems and related products subject to change without notice.

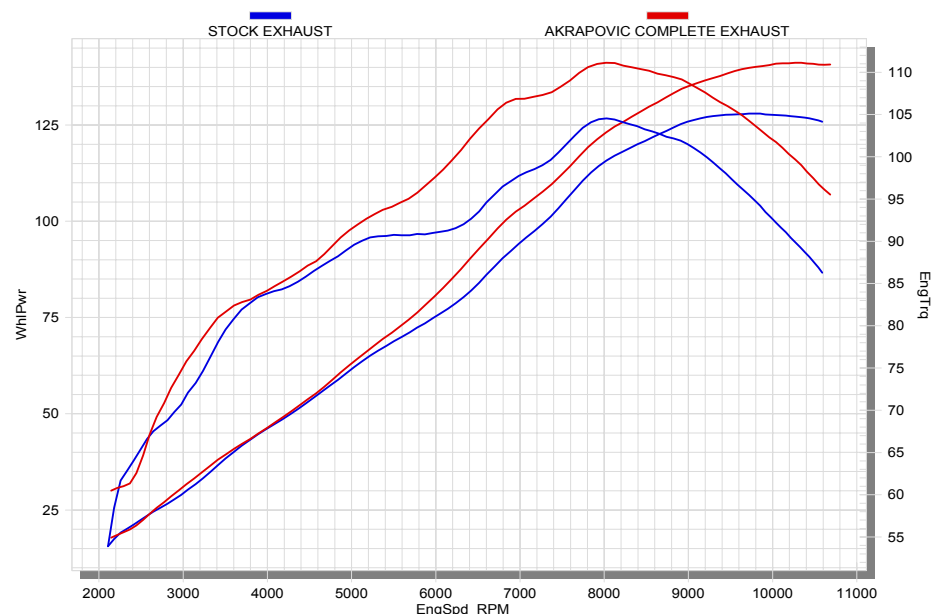

Product code: (111959) S-K10R6-ZC ; (111960) S-K10R6-ZT racing
 (111961) S-K10R6-ZC/1 ; (111962) S-K10R6-ZT/1 racing headers + street legal mufflers



WARNING! IN CASE OF COMBINATION WITH RACING LINE TUBE SET, THE SLIP-ON HOMOLOGATION IS NOT VALID!

**KAWASAKI Z 1000 / RACING LINE with Slip-on street legal mufflers, fits on Z1000SX with side cases / OPEN
KAWASAKI Z 1000SX**

**Product code: S-K10R6-ZC/3
S-K10R6-ZT/3**

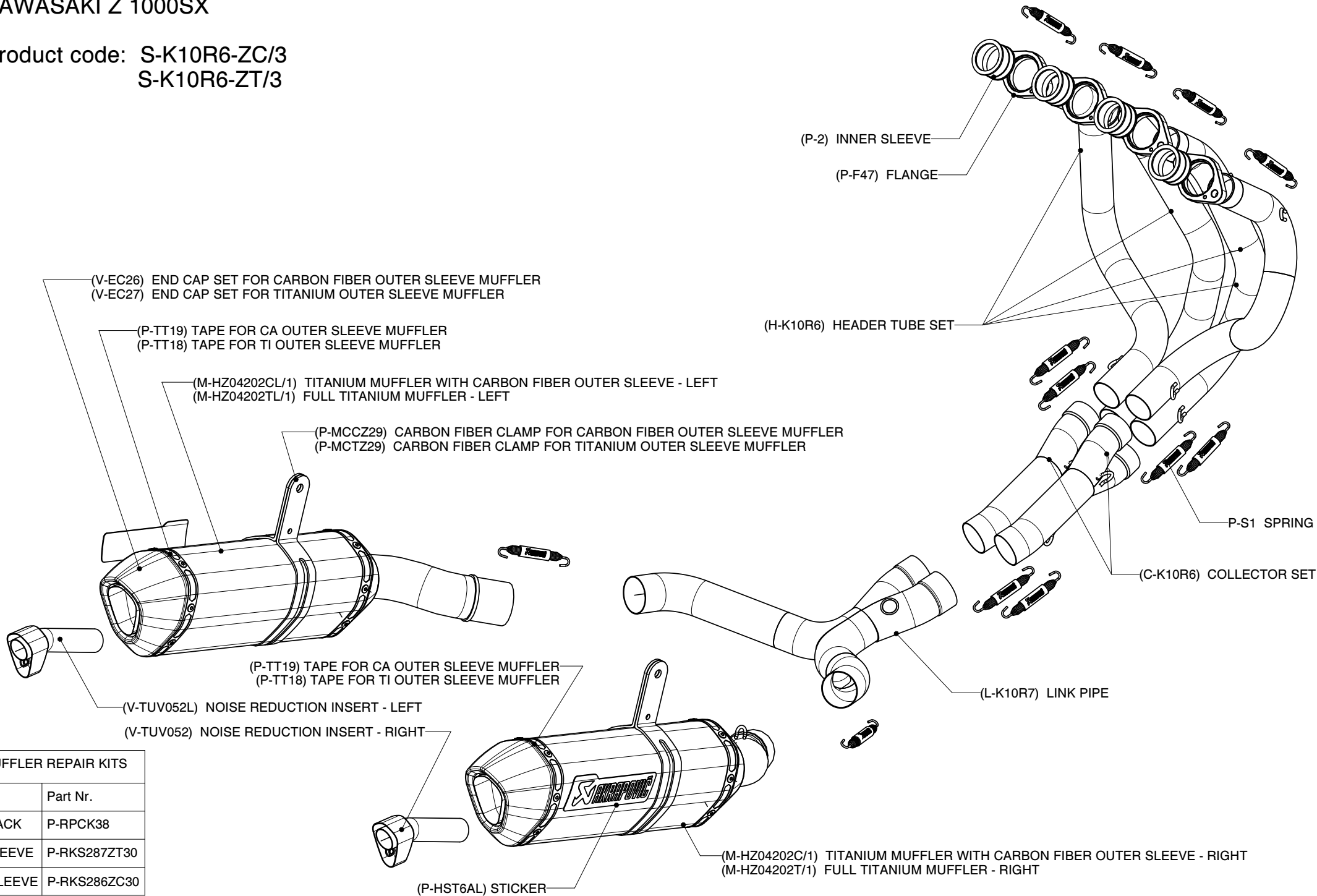

MUFFLER REPAIR KITS

KIT	Part Nr.
REPACK	P-RPCK38
Ti SLEEVE	P-RKS287ZT30
Ca SLEEVE	P-RKS286ZC30