



Suzuki DR-Z 400E (2002 - 2004)
Kawasaki KLX 400R (2003)

Evolution Exhaust System

Akrapovic Evolution Exhaust System

for the SUZUKI DR-Z 400E (2002 - 2004), Kawasaki KLX 400R (2003)

This Akrapovic EVOLUTION system is designed for energetic riders of the 2004 Suzuki DR-Z 400E, and due to the similarities of the bikes also the 2003 Kawasaki KLX 400R. The system offers improved engine performance at nearly half the weight of the stock system, and in addition is significantly quieter. The system does not fit on the DR-Z 400 S.

PERFORMANCE

Measurements of the Akrapovic EVOLUTION system on the SUZUKI DR-Z 400E (without noise damper):

Power: the system is designed to provide increased power at the top of the rpm range. There is a marked improvement over stock performance. In the rest of the range the Akrapovic curve follows the stock power curve.

Torque: the torque curve also follows the stock curve up to about 7000 rpm. From there on our system offers significantly more torque, which unlike the stock system continues into the top end of the range.

CONFIGURATION

The system is composed of a conical titanium header tube connected to a conical titanium link pipe. The connection is a free-floating joint held together with a silicon-shielded tensioning spring. The link pipe is welded to the muffler, forming a single component. The muffler is made entirely of titanium, and is connected to the frame using a carbon-fiber clamp.

	PERFORMANCE		
	stock	AKRAPOVIC	max. increased power
max. rear wheel power HP / rpm (measured on SuperFlow Cycle Dyn)	40.1 / 9200	41.2 / 8300	2.1 / 8300

	CONFIGURATION		
	header tubes	collector	link pipe
material	TITANIUM	-	TITANIUM
tube shape	CONICAL	-	CONICAL

interference crossover tubes	-	lambda sensor	-
header tube inner sleeves	S.S. CNC MACHINED	header tube flanges	S.S. CNC MACHINED
header tubes - collector connection	-	collector / header tube - link pipe connection	FREE FLOATING + SILICON SHILDED SPRING
link pipe - muffler connection	WELDED	muffler inlet cap / outlet cap	TITANIUM / TITANIUM
muffler metal interior	TITANIUM	muffler outer sleeve	TITANIUM
muffler clamp	CARBON-FIBER OFF ROAD	muffler bracket	-
noise damper	-	heat shield	-

OPTIONS			
link pipe	noise damper	muffler bracket	heat shield
-	-	-	-

	ADDITIONAL DATA				
	stock	AKRAPOVIC		difference	
		RACING	EVOLUTION	stock - RACING	stock - EVOLUTION
weight comparison (kg)	5.32	-	2.77	-	2.55
noise measurements (dB / rpm)	stock		AKRAPOVIC		
	103.1 / 4500		98.8 / 4500		
possibility of periodic service without removing A.E.S.	oil		oil filter		
	YES		YES		
legal for street use	NO				

Technical specifications of Akrapovic exhaust systems and related products subject to change without notice.

Akrapovic Evolution Exhaust System

for the SUZUKI DR-Z 400E (2002 - 2004), Kawasaki KLX 400R (2003)

Akrapovic Exhaust System Technology copyright 2004, all rights reserved



ANTI-SEIZING GREASE

CARBON-FIBER
MUFFLER CLAMP



Akrapovic Evolution Exhaust System

for the SUZUKI DR-Z 400E (2002 - 2004), Kawasaki KLX 400R (2003)



Akrapovic Exhaust System Technology copyright 2004, all rights reserved

Off-Road
Program

Akrapovic Evolution Exhaust System

for the SUZUKI DR-Z 400E (2002 - 2004), Kawasaki KLX 400R (2003)



Akrapovic Exhaust System Technology copyright 2004, all rights reserved

Off-Road
Program

Product code: 103233 (S-S4MET2-MTT)

Akrapovic Evolution Exhaust System

for the SUZUKI DR-Z 400E (2002 - 2004), Kawasaki KLX 400R (2003)

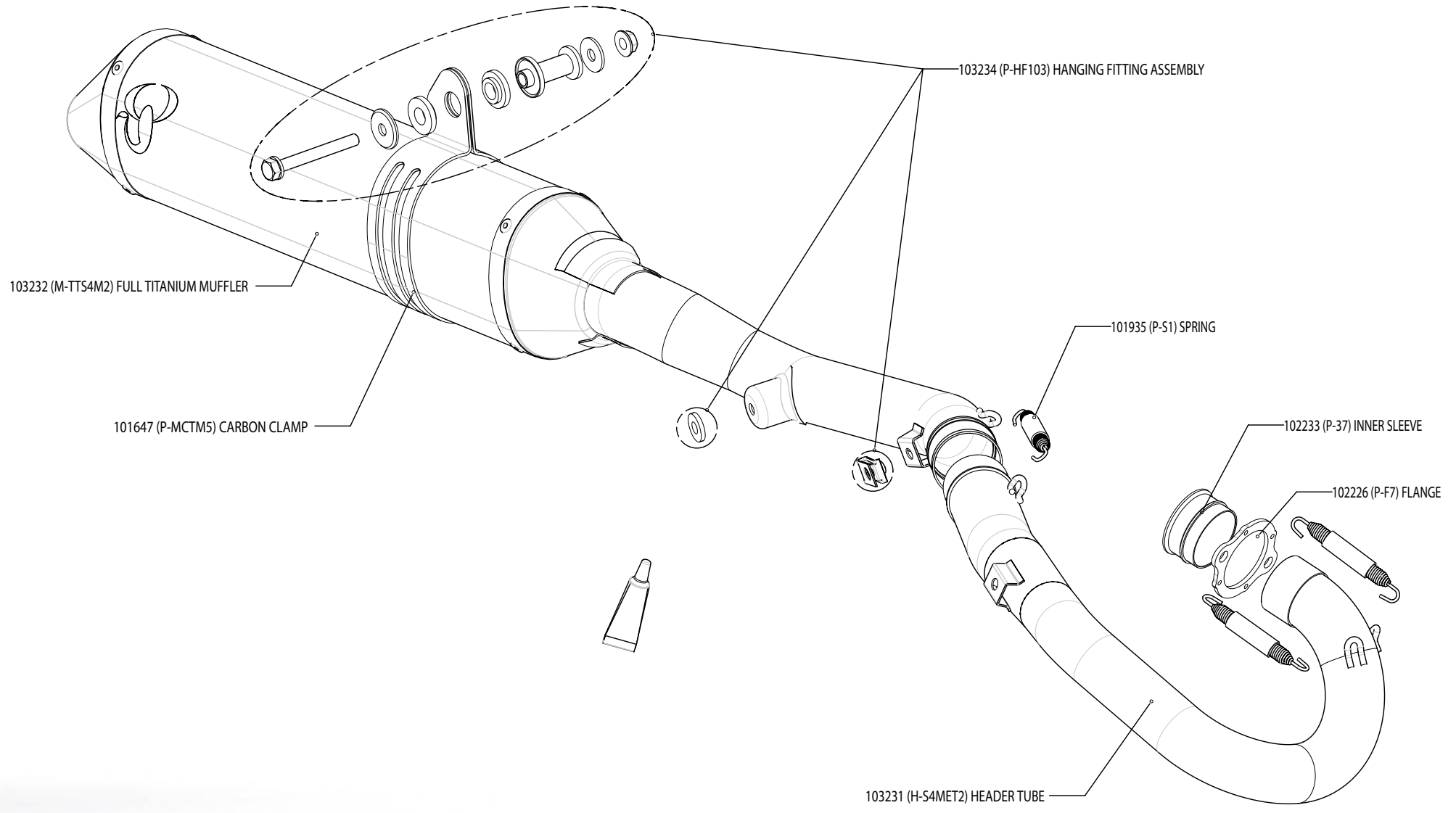

Off-Road Program

Akrapovic Evolution Exhaust System

for the SUZUKI DR-Z 400E (2002 - 2004), Kawasaki KLX 400R (2003)

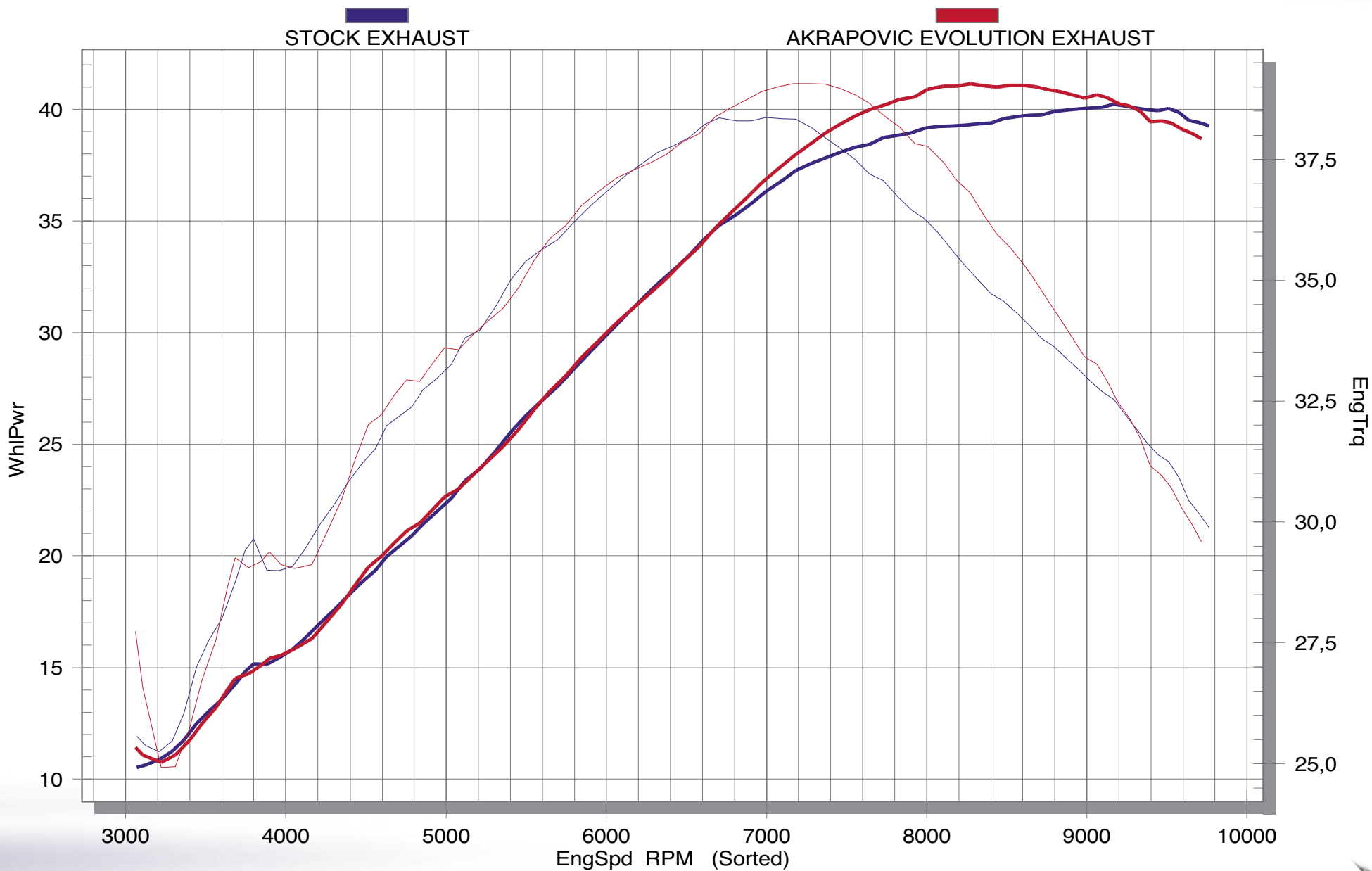

Akrapovic Exhaust System Technology copyright 2004, all rights reserved

Off-Road Program

